

# 2D LASER PROFILE SENSOR

## PS-30

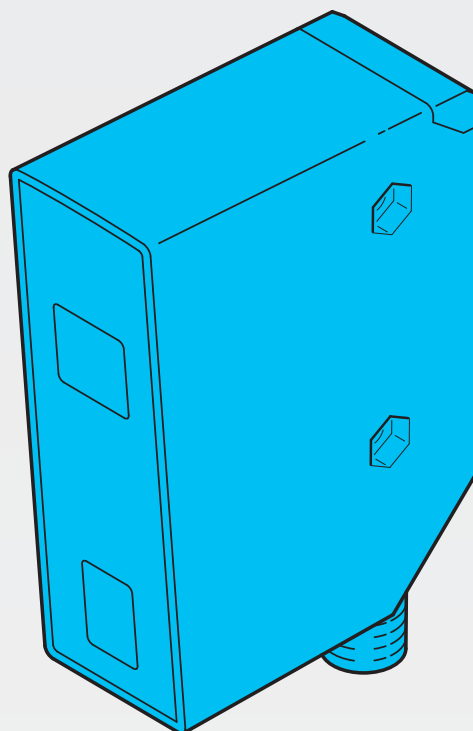

600015-0000EN · Rev 1 · 2022/03

OPERATING INSTRUCTIONS

# CONTENTS

<b>1 PRELIMINARY NOTE</b>	<b>4</b>
1.1 Symbols used .....	4
1.2 Warning signs used .....	4
<b>2 SAFETY INSTRUCTIONS</b>	<b>5</b>
<b>3 INTENDED USE</b>	<b>6</b>
3.1 General description .....	6
3.1.1 Teach process and height profile .....	7
3.1.2 Normal operation .....	7
3.2 Interpretation of the similarity value .....	8
3.2.1 Fluctuation of the matching value .....	8
3.3 Profile properties .....	9
3.4 Areas of application .....	9
<b>4 FUNCTION</b>	<b>10</b>
4.1 Operating modes .....	10
4.1.1 Switching mode .....	10
4.1.2 Operation with IO-Link master .....	10
<b>5 INSTALLATION</b>	<b>11</b>
5.1 Installation conditions .....	11
5.2 Installation instructions .....	11
5.2.1 Lateral inclination .....	11
5.2.2 Front inclination .....	12
5.2.3 Saturation and signal loss .....	12
5.2.4 Preventing multiple reflections .....	13
5.2.5 Preventing soiling and ambient light .....	13
<b>6 ELECTRICAL CONNECTION</b>	<b>14</b>
6.1 Operation with IO-Link master .....	14
<b>7 OPERATING AND DISPLAY ELEMENTS</b>	<b>15</b>
<b>8 SET-UP</b>	<b>15</b>
8.1 Guided teach / Teach process for reference profiles .....	16
8.1.1 Selecting languages .....	16
8.1.2 Teaching objects .....	16
8.1.3 Setting the profile range (ROI) .....	17
8.1.4 Setting the position of the reference profile .....	18
8.1.5 Switching threshold .....	18
8.1.6 Saving reference profiles .....	19
8.1.7 Finishing the teaching process .....	20
8.1.8 Run mode .....	20
<b>9 MENU</b>	<b>21</b>
9.1 Basic functions .....	21
9.2 Extended functions .....	22



<b>10 OPERATING MODES</b>	<b>24</b>
10.1 Continuous mode.....	24
10.2 Triggered mode.....	24
<b>11 PARAMETER SETTING</b>	<b>26</b>
11.1 Parameter level basic functions.....	26
11.1.1 [Adjust threshold].....	26
11.1.2 [ROI marker].....	26
11.1.3 [Profile properties].....	26
11.1.4 [Profile manager].....	26
11.1.5 [Extended functions].....	27
11.1.6 [Back].....	27
11.2 Parameter level extended functions.....	27
11.2.1 [Factory setting].....	27
11.2.2 [Device information].....	27
11.2.3 [Configuration].....	27
11.2.4 [Display].....	28
11.2.5 [Back].....	28
11.3 [Configuration] submenu.....	28
11.3.1 [Triggered mode].....	28
11.3.2 [Trigger source].....	28
11.3.3 [Output mode].....	28
11.3.4 [Trigger delay].....	29
11.3.5 [Integration time].....	29
11.3.6 [Output function].....	29
11.3.7 [Output logic].....	29
11.3.8 [Profile source select].....	29
11.3.9 [Back].....	29
11.4 [Display] submenu.....	30
11.4.1 [Brightness].....	30
11.4.2 [Color].....	30
11.4.3 [Language].....	30
11.4.4 [Back].....	30
11.5 IO-Link.....	31
11.5.1 General information.....	31
11.5.2 Device-specific information.....	31
11.5.3 Parameter setting tools.....	31
11.5.4 Functional scope.....	31
<b>12 TROUBLESHOOTING</b>	<b>32</b>
12.1 Error messages on the display.....	32
12.2 Other errors.....	32
<b>13 MAINTENANCE, REPAIRS, DISPOSAL</b>	<b>33</b>
<b>14 DIMENSIONAL DRAWING</b>	<b>33</b>
<b>15 FACTORY SETTING</b>	<b>33</b>

## 1 PRELIMINARY NOTE

Instructions, technical data, approvals and other information via QR code on the device / on the packaging or at [www.di-soric.com](http://www.di-soric.com).

### 1.1 SYMBOLS USED

---

- ✓ Prerequisites
- ▶ Handling instructions
- ▷ Reaction, result
- [...] Designation of keys, buttons or displays
- Cross-reference
-  Important information  
Malfunctions or faults are possible if not observed
-  Information  
Additional information

### 1.2 WARNING SIGNS USED

---

**CAUTION**

Warning of personal injury

- ▷ Minor, reversible injuries are possible.

## 2 SAFETY INSTRUCTIONS

- The device described is integrated as a subcomponent in one system.
  - The safety of this system is the responsibility of the manufacturer.
  - The system manufacturer is obligated to perform a risk assessment and use this to generate and include documentation regarding the legal and standard requirements for operators and users of the system. This must include all required information and safety information for the operator, user and, if necessary, service personnel authorized by the system manufacturer.
- This document must be read before product commissioning and stored for its service life.
- The product must be unconditionally suited for the respective applications and environmental conditions.
- The product must only be used for its intended purpose (→ Intended use).
- The failure to comply with application instructions or technical information can lead to property and/or personal damages.
- The manufacturer is not liable and/or will not accept any warranty claims for consequences due to interference with the product or misuse by the operator.
- Assembly, electrical connection, commissioning, operation and maintenance of the product may only be performed by authorized technical personnel trained by the system operator.
- Devices and cables must be suitably protected against damage.



### CAUTION

Radiation exposure

- ▷ Injury due to hazardous radiation exposure
- ▶ Only the operating and adjustment equipment listed in the operating instructions must be used.



### CAUTION

Visible laser light LASER CLASS 1.

EN/IEC 60825-1 : 2007 and EN/IEC 60825-1 : 2014 corresponds to 21 CFR Part 1040 with the exception of the deviations in coordination with Laser Notice No. 50, June 2007.

#### Position of the product cable

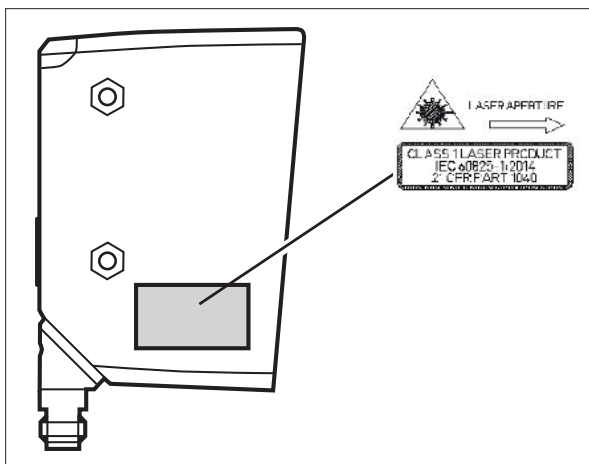

#### Information sign



## 3 INTENDED USE

### 3.1 GENERAL DESCRIPTION

The sensor projects a laser line on the object and determines the height profile of the object along the laser line using a triangulation process.

The object to be detected must be in the operating range of the sensor for this to occur.

The sensor has a trapezoidal operating range, defined as follows:

- Spacing to sensor (Z direction): 150 to 300 mm
- Length of profile (X direction):
  - for an object distance of 150 mm: 45 mm
  - for an object distance of 300 mm: 90 mm

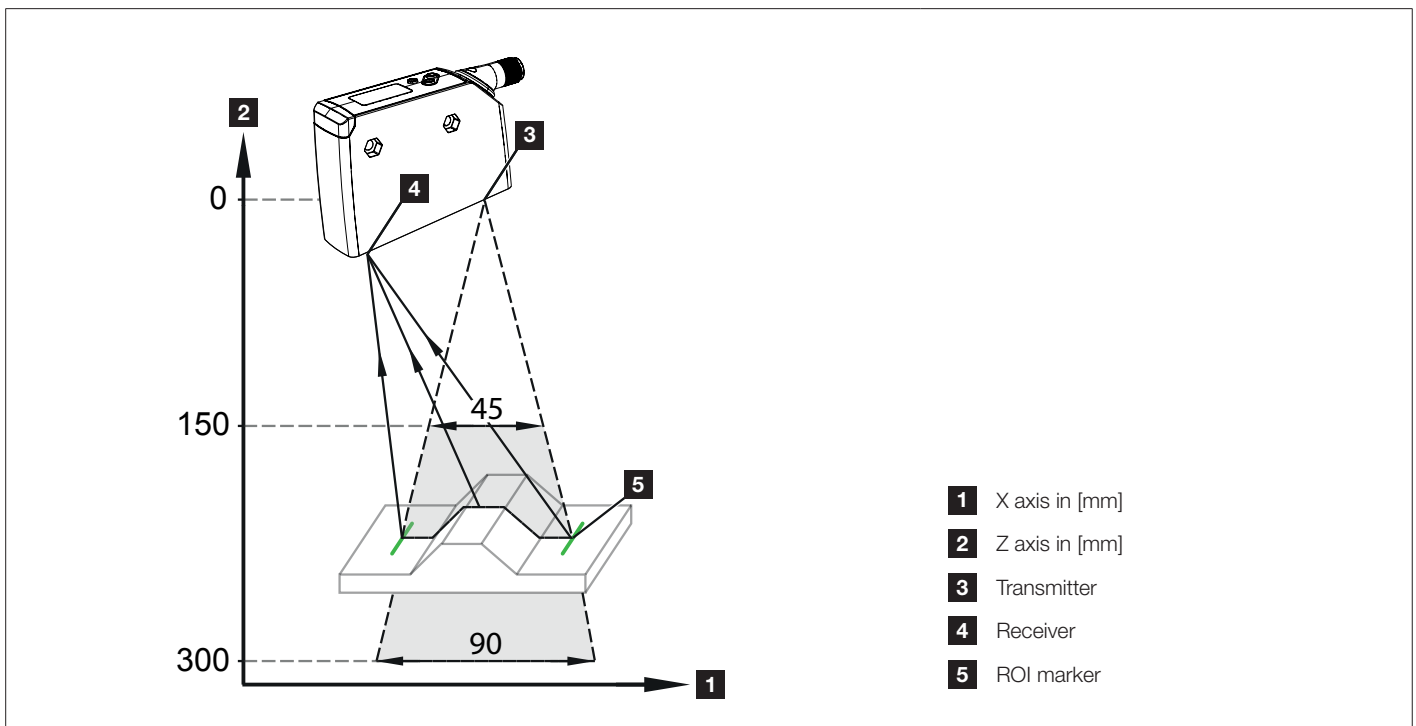

Fig. 1: General representation



The projected laser line is wider than the operating range. The object to be detected should be positioned centrally along the laser line.



The operating range in the X direction is displayed by two green, projected, vertical ROI markers during the "guided teach." The ROI markers can also be switched on during operation.



- ▶ Object is located outside of the operating range.
- ▷ Laser line flashes and the [Object out of range] appears on the display.

### 3.1.1 TEACH PROCESS AND HEIGHT PROFILE

The sensor is taught in the first work step (teach process). This process also applies the entire height profile determined by the laser line. The user then has the option to further limit the relevant profile range (ROI).

- The height profile from this profile range (ROI) is then saved as a taught reference profile.
- Up to 10 reference profiles, including all associated setting parameters, can be taught and saved.  
A reference profile can then be activated from the memory.

In the next step, the sensor continually detects the height profile, compares this to the activated reference profile and then generates a matching value. The user can now determine a switching threshold → “3.2 Interpretation of the similarity value”, page 8

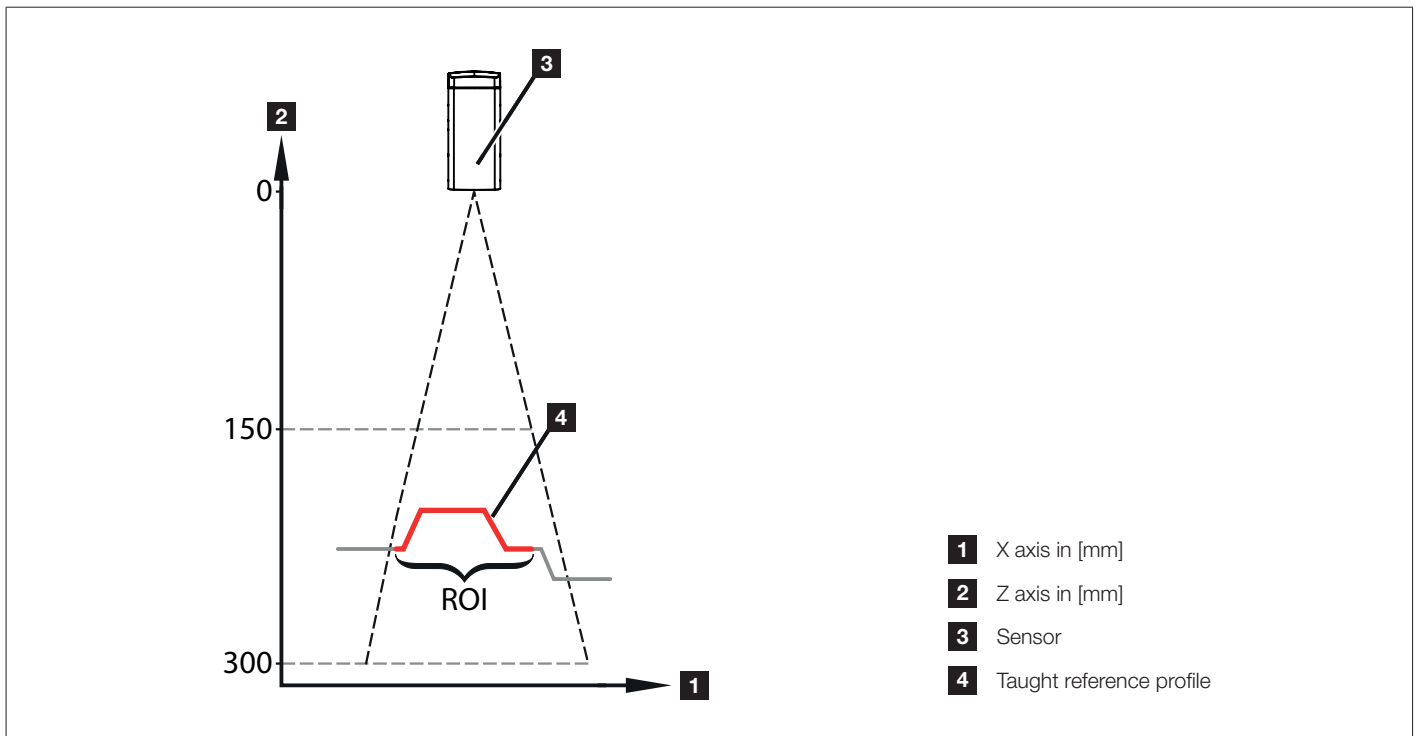

Fig. 2: Height profile

### 3.1.2 NORMAL OPERATION

In normal operation, the sensor detects height profiles, either continually or triggered, and compares these to the activated reference profile to generate a matching value.

The height profiles are referenced to a max. measuring distance = 300 mm (reference height). The reference point for the reference height is the optical zero point of the transmitter unit. This is located in the interior of the sensor.

Example: An object is approx. 200 mm from the sensor. In the IO-Link master, the height profile is displayed in a base height of approx. 100 mm.

- Profile heights reference the reference height and thus have positive absolute values.
- All data sheet information refer to the dimensions of the object profiles and not to the absolute distances to the sensor. The object profiles are displayed with real dimensions (object profile width / height) independent of their position in the operating range.

### 3.2 INTERPRETATION OF THE SIMILARITY VALUE

The measured height profile (also called "profile" in the following) is compared internally with an active reference profile. The degree of similarity generates the internal measured value (matching value).

The measured value determined by the sensor thus represents the degree of similarity of the measured profile to the activated reference profile.

Output matching value in [%]	Description
100	Measured profile conforms 100% to the activated reference profile.
50	Measured profile conforms 50% to the activated reference profile.

**!** The tolerance level of the matching value must be determined by the user during commissioning and should be used as a switching threshold for the following differentiation:

- Good parts
- Bad parts

The transition between good parts and bad parts is determined by measurement and is used as a suitable switching threshold.

**i** There is no general recommendation for a switching threshold. This must be determined for each individual application.

#### 3.2.1 FLUCTUATION OF THE MATCHING VALUE

Natural fluctuations (noise, drift) are detected in the measured matching value.

These measurement fluctuations mean that the matching value itself is normally < 100% for a re-measurement of the taught object.

The measurement uncertainty, which the sensor uses to determine the height profiles, is described via the following parameters:

Gz - accuracy in the Z direction (profile height)

Gx - accuracy in the X direction (profile width)

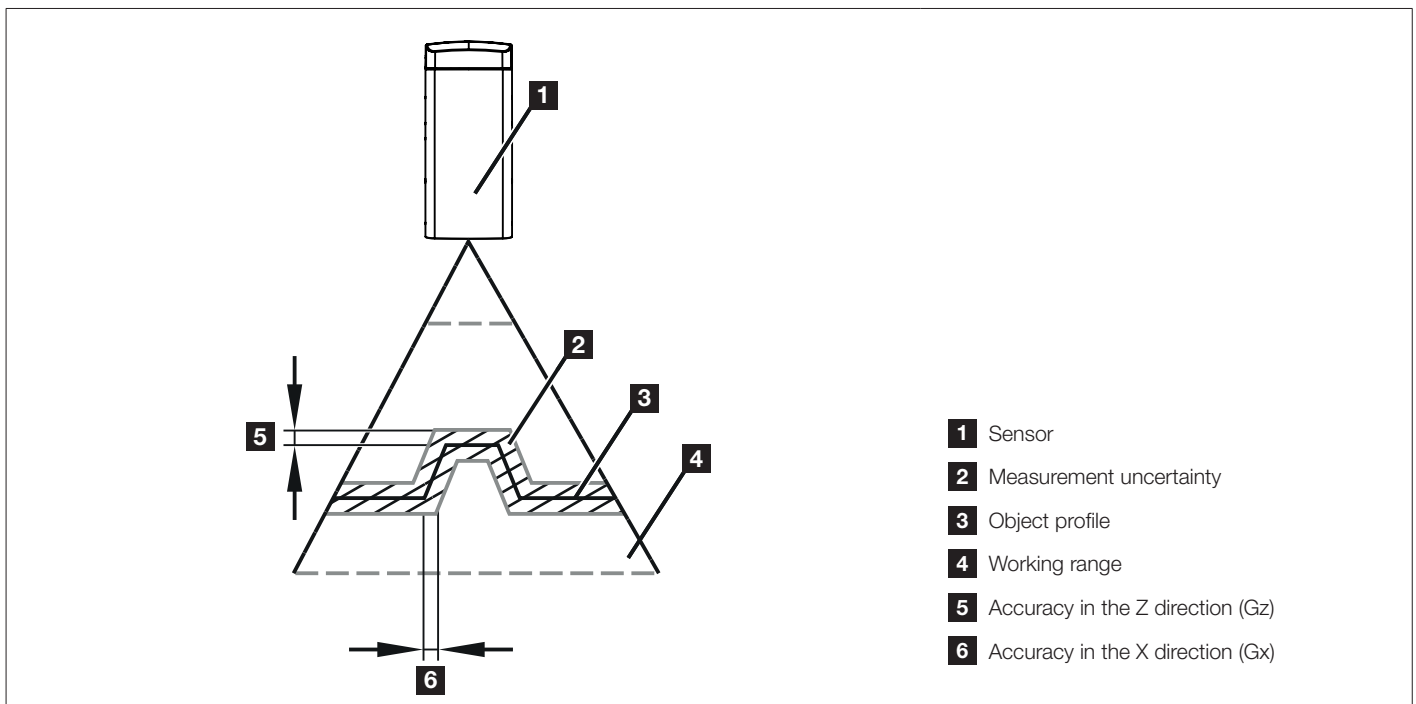

Fig. 3: Accuracy



Gz / Gx also directly defines:

- minimum object height to be detected reliably
- minimum object width to be detected reliably



The height profiles are determined by the sensor with a higher resolution than Gz / Gx. Changes to the object height / width can thus be detected within the measurement uncertainty.

### 3.3 PROFILE PROPERTIES

The status parameter [Profile properties] indicates the relative share of valid measurement values in the height profile. It only takes into account the profile range selected by the user. The parameter can be applied as an indicator for the profile quality during ongoing operation → “11.1 Parameter level basic functions”, page 26

Parameter value [%]	Description
50	50% of the data points in the measured height profile are valid and are used for determining the matching value. Invalid values are not taken into account.



Ideally, the status parameter [Profile properties] should be applied and saved directly after the teaching process with the taught object (reference object). The profile quality can be checked at any time with this reference object during operation.

If the value has reduced significantly, e.g. due to changes to the sensor position, a new teaching process for the object would make sense.



The status parameter can be constantly monitored via the IO-Link master. The status parameter can also be used for optimizing the sensor position during the teaching process.

### 3.4 AREAS OF APPLICATION

The optical sensor is primarily suited for process quality assurance within the scope of workpiece shape monitoring and error detection.

Examples:

- Monitoring of the processing quality, e.g. the diameter of drill holes.
- Monitoring of workpieces for faulty processing, e.g. drill hole errors.



The workpiece must be at a standstill during the measurement.

The continuous measurement mode must be selected for static situations. The sensor permanently monitors the workpiece and reports deviations to the active reference profile → “10.1 Continuous mode”, page 24

The triggered measurement mode must be selected for dynamic situations. A superordinate process control unit decides when the detection takes place, thus ensuring that the workpiece is located and is at a standstill in the detection range → “10.2 Triggered mode”, page 24

## 4 FUNCTION

The optical sensor continually detects or triggers the height profile of the object in the operating range according to the triangulation principle. The optical sensor also has an IO-Link interface.

The sensor can be operated in three different modes of operation:

- “Switching mode” → page 10
- “Operation with an IO-Link master” → page 10

### 4.1 OPERATING MODES

#### 4.1.1 SWITCHING MODE

In switching mode, the sensor is directly connected to the process control unit and transmits information on good part / bad part via the switching output.

 If the set switching threshold is exceeded/not reached, this is signaled by means of switching signals on switching output 1/2. The switching outputs act complementary → **“6 Electrical connection”, page 14**

As an option, the time at which the measurement is taken can be controlled by a process control unit via the trigger input (pin 5). The sensor reports the successful start of the measurement and the presence of the switching information via switching output 2. The superordinate process control unit has full control of the detection time period. → **“10.2 Triggered mode”, page 24**

#### 4.1.2 OPERATION WITH IO-LINK MASTER

If the sensor is linked to an IO-Link master, the parameterization, triggering and data recording can take place completely via IO-Link. The cyclical process data contain the matching value and the switching information (good part / bad part).

Additional functionalities are available via IO-Link:

- Detection of the number of trigger operations
- Device identification
- Two profile ranges (ROIs), when activating the ROI marker, the two ROIs are displayed via two green marker pairs.
- Laser switch-off
- Profile heights
- Object offset in X / Z direction
- Statistical evaluations

 Further information  
[www.di-soric.com](http://www.di-soric.com) → 213740 → Downloads → IODD

## 5 INSTALLATION

### 5.1 INSTALLATION CONDITIONS

- ▶ Mount the device so that the object to be detected is in the detection range of the sensor.
- ▶ Use two M4 screws to secure the device for direct mounting.



Additional accessories → [www.di-soric.com](http://www.di-soric.com) → Accessories.

### 5.2 INSTALLATION INSTRUCTIONS

#### 5.2.1 LATERAL INCLINATION

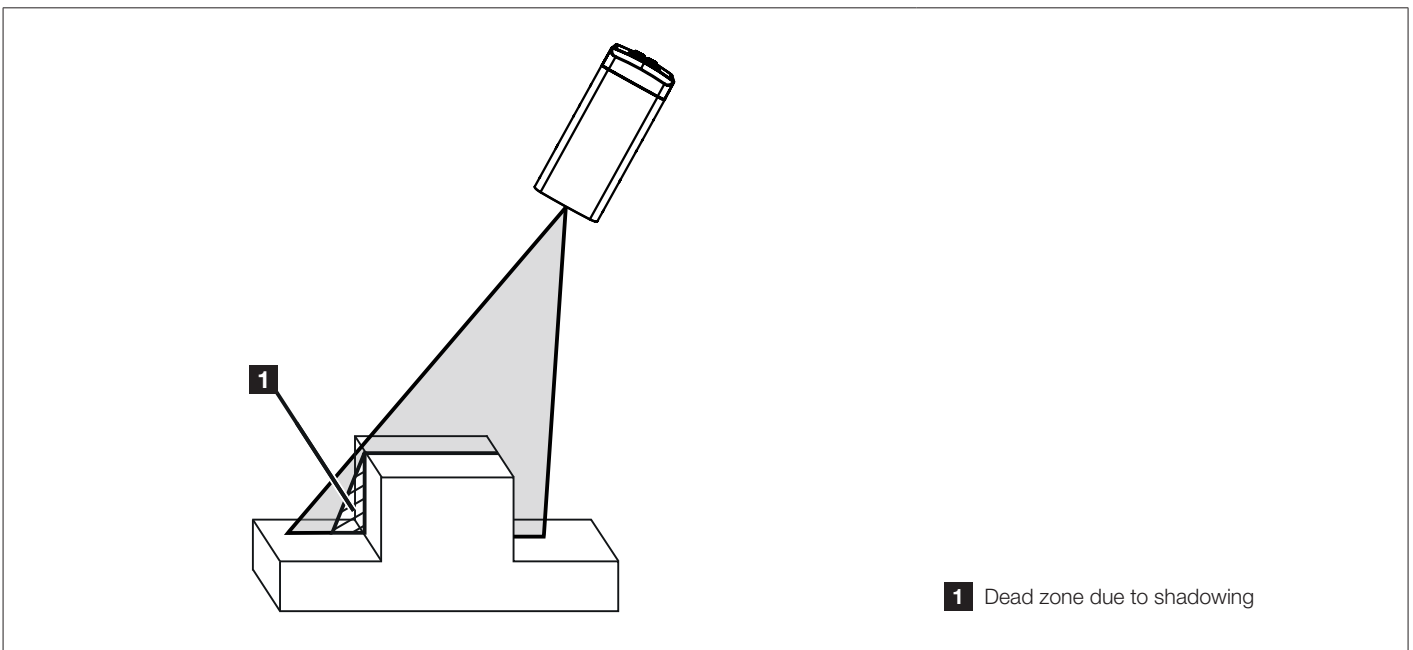

Fig. 4: Lateral inclination

The sensor should be aligned as vertically as possible to the object to be detected. In case of lateral inclination and vertical object edges, the laser line will be partially interrupted. The profile cannot be detected in this area. This can be prevented by reducing the inclination angle.

### 5.2.2 FRONT INCLINATION

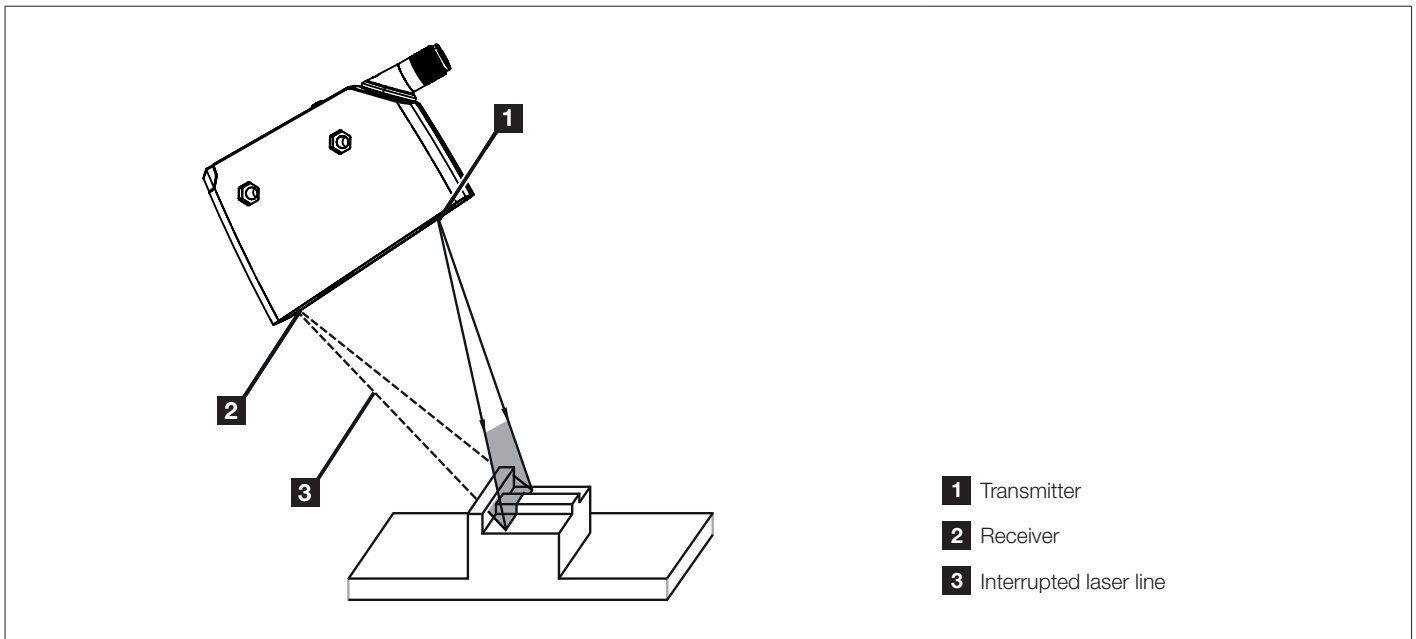

Fig. 5: Front inclination

If the sensor inclination is from the front or rear, it must be ensured that the laser line reflected by the object can be detected by the receiver.

Reducing the inclination angle or rotating the sensor 180° can ensure that the receiver detects the laser line.

### 5.2.3 SATURATION AND SIGNAL LOSS

The sensor automatically regulates the exposure time for capturing the height profile to prevent saturation.

Highly reflective surfaces reflect the laser light in the direction of the sensor with extreme contrasts. In some cases, this leads to individual points within the profile range (ROI) that can no longer be detected.

Signal losses can be avoided by a slight change to the sensor position.

- incline the sensor laterally or frontally
- increase or decrease the object distance

### 5.2.4 PREVENTING MULTIPLE REFLECTIONS

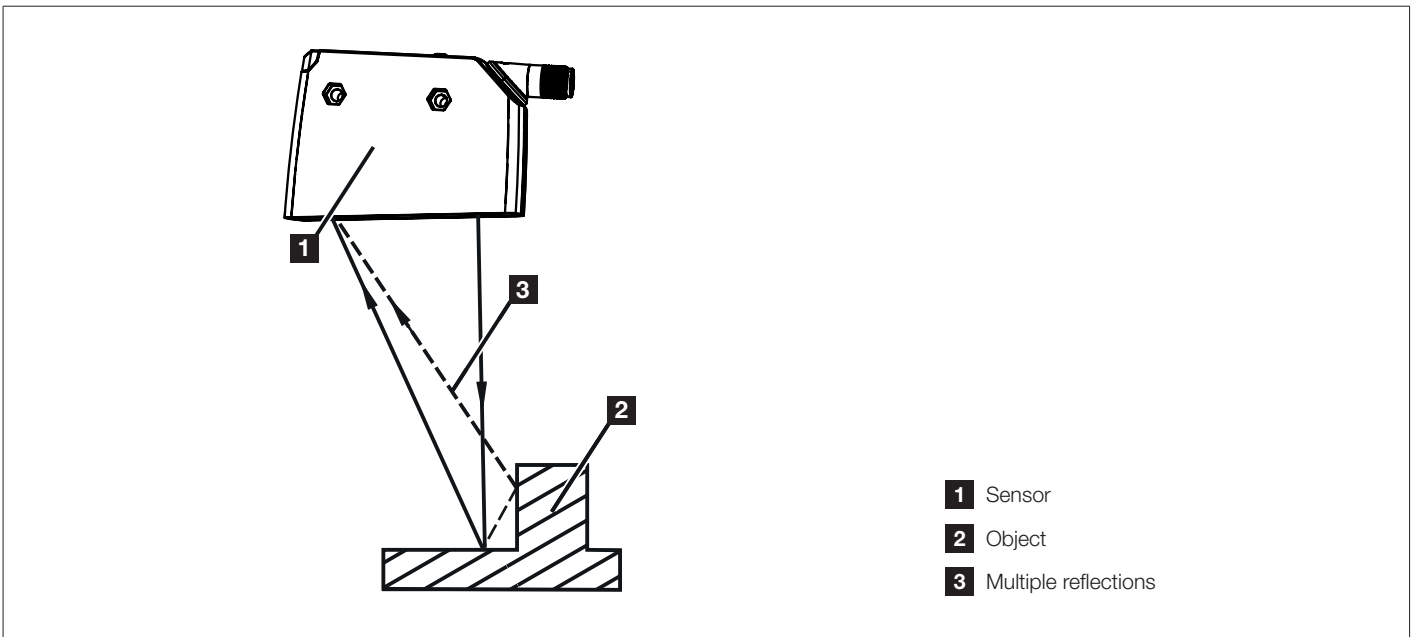

Fig. 6: Multiple reflections

- Change the sensor position slightly, e.g. lateral or front inclination, reduce / increase spacing to object.

### 5.2.5 PREVENTING SOILING AND AMBIENT LIGHT

Optical sensors should preferably be set up with the front panel downwards or parallel to the ground surface.

Background:

- Optical sensors are sensitive to direct radiation from light sources. Common light sources (lamps, sun) typically radiate from above.
- Optical sensors react sensitively to soiling because this reduces the operating reserve.



Dust deposits can be reduced by a downward or lateral installation. This can help to achieve longer cleaning intervals.



It must be noted that sensors that are installed with the front panel pointing upwards should not be aimed at skylights or ceiling lights.

## 6 ELECTRICAL CONNECTION



The device may only be installed by a qualified electrician.

- ▶ You must follow all national and international provisions regarding the setup of electro-technical systems.
  - ▶ Ensure a voltage supply according to EN 50178, SELV, PELV. PS30-05LL-500-500-IBS: cULus, Supply Class 2
- ▶ Disconnect the system from the mains.
- ▶ Connect the device as follows:

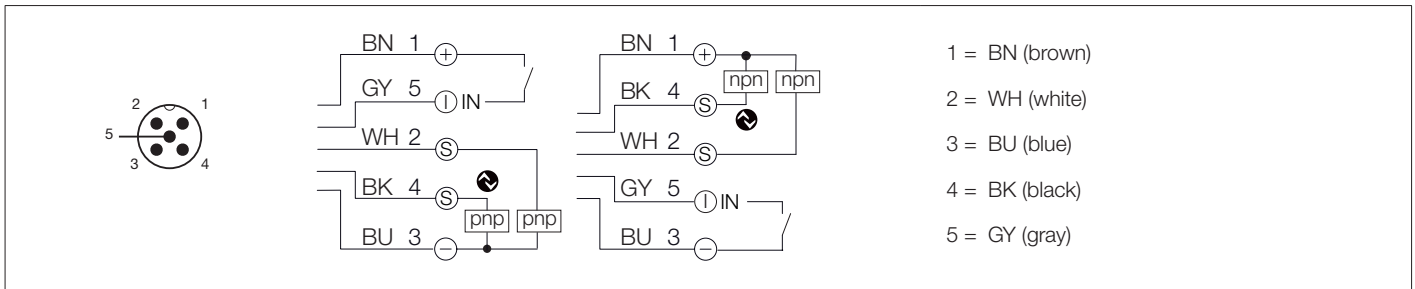

Fig. 7: Circuit diagram (color designation according to DIN EN 60947-5-2)

Pin	Continuous mode (factory setting)	Triggered mode
1	VDD	VDD
2	OUT2 = switching output	OUT2 = readiness signal (switching output)
3	GND	GND
4	OUT1 = switching output / IO-Link	OUT1 = switching output / IO-Link
5	Laser ON / OFF*	PLC trigger input

\*) This function is activated / deactivated via IO-Link.



In the “Continuous mode” operating mode, OUT1 and OUT2 are configured as complementary switching outputs.  
 → “10.1 Continuous mode”, page 24

In the “Triggered mode” operating mode, OUT2 is configured as a readiness signal. → “10.2 Triggered mode”, page 24



Complementary outputs transmit the same sensor information with oppositional logic levels. This means that both an opener and a closer switching output are available at the same time.

OUT1 can be used, e.g. for the detection of good parts, while OUT2 can signal the detection of bad parts.

### 6.1 OPERATION WITH IO-LINK MASTER

The device is compatible with IO-Link master port class A (type A).



When operating with IO-Link master port class B (type B), please note the following:

By default, the device is not compatible with master port class B (Type B). Pin 2 and pin 5 are used for manufacturer-specific functions. This means that the main supply voltage of the device and the additional voltage supply (master port class B on pin 2/5) cannot be galvanically isolated.

The device can be used with master port class B using the following configuration:

- Connect the device and the IO-Link master via 3 wires: Connect pin 1, 3 and 4 of the device to the IO-Link master (do not connect pin 2 and 5).

## 7 OPERATING AND DISPLAY ELEMENTS

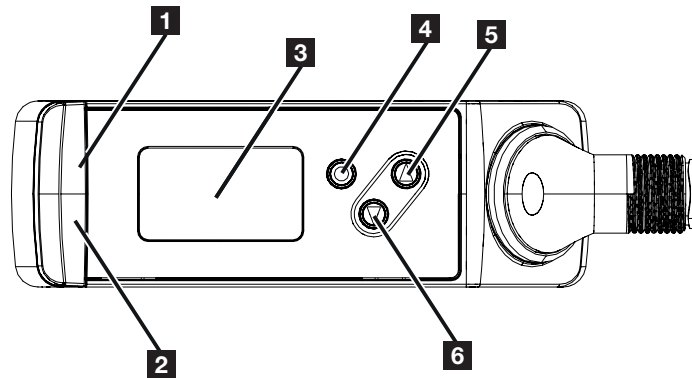

<b>1</b>	1x LED yellow	Switching state OUT1
<b>2</b>	1x LED green	Lit LED = Power
<b>3</b>	Graphic display	Display of the measured matching value.
<b>4</b>	Programming button [●]	Selects parameters and confirms parameter values.
<b>5</b>	Programming button [▲]	Sets parameter values (scrolling by holding pressed, incrementally by pressing once).
<b>6</b>	Programming button [▼]	Sets parameter values (scrolling by holding pressed, incrementally by pressing once).



The programming buttons can be locked and unlocked using the following step:  
Press and hold [▲] + [▼] for 10 s.



Pressing [▲] + [▼] simultaneously takes you back to the menu guide.

## 8 SET-UP

- ▶ Check whether or not the device is operating properly after installation, electrical connection and programming.
- ▷ If the initial set-up is correct, the sensor starts with “Guided teach” → “8.1 Guided teach / Teach process for reference profiles”, page 16.  
The sensor saves the most recent settings made internally.



When the sensor is switched on for the first time after a reset, it goes back to “Guided teach” because a reset will delete the taught reference profile.



Service life of a laser diode: 50,000 hours



The sensor should not be moved again after a successful teach process. The activated reference profile will no longer be reliably detected any time there is a change to the sensor position.  
The sensor must be re-taught after each position change.



The sensor requires a warm-up period of  $\geq 10$  min. The performance parameters specified in the data sheet only apply after this warm-up period.

The teaching of objects should also only be done in a warmed-up state.

## 8.1 GUIDED TEACH / TEACH PROCESS FOR REFERENCE PROFILES

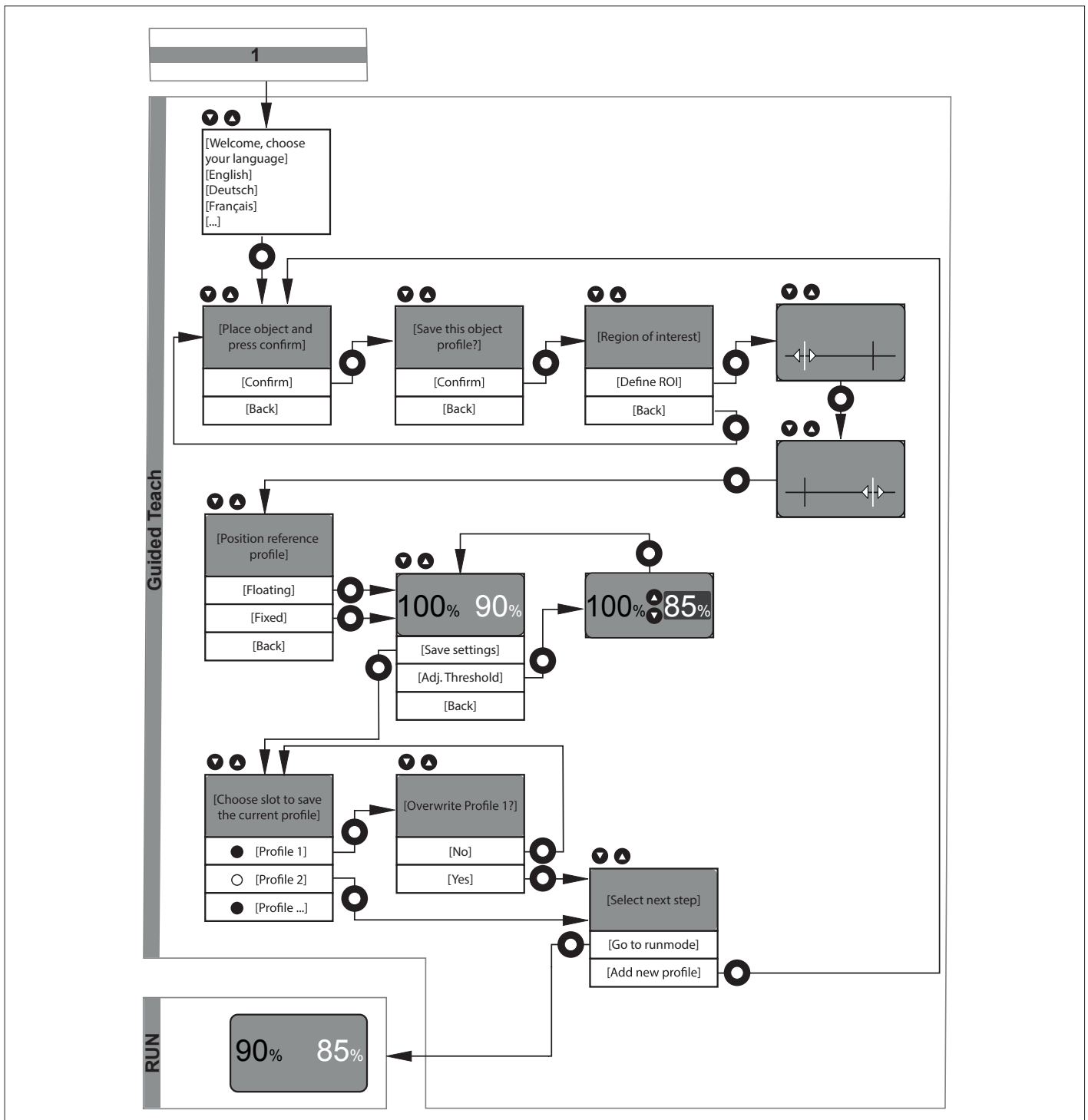

### 8.1.1 SELECTING LANGUAGES

- ▶ Activate the sensor.
- ▷ The available languages are shown on the display.
- ▶ Select the desired language with [▲] / [▼] and confirm with [●].

### 8.1.2 TEACHING OBJECTS

- ▶ The teaching of profiles is introduced in the next step.
- ▷ The prompt [Place object and press confirm] appears on the display.



- ▷ The sensor emits a red laser line with two vertical green ROI markers.
- ▶ Position the sensor so that the laser line scans the area to be monitored and the object is within the operating range of 150 to 300 mm → **“3.1 General description”, page 6.**
- ▶ Start the teach process with [●].
- ▷ The sensor makes multiple measurements of the profile of the object / background.
- ▶ Use [▲] / [▼], to select [Confirm] or [Back] and press [●].

[Confirm]: Taught profile is saved.

[Back]: Re-teach the profile.

 The object should not be moved during the measurement. The end of the measurement is also signaled to the display by two flashes of the laser line.

 If the object to be detected is outside of the operating range (e.g. closer than 150 mm or farther than 300 mm), the teach process will be aborted. The message [Object outside of range] will appear for three seconds. Then a new teach process is started.

### 8.1.3 SETTING THE PROFILE RANGE (ROI)

The sensor gives you the option to select a relevant profile range (ROI) from the entire taught height profile. The profile section contained in this profile range (ROI) is saved as a reference profile and is then used to determine the matching value.

 Using this limitation, the evaluation of the height profile can be reduced to the relevant characteristic. Deviations at irrelevant locations are not taken into account.

- ▶ In the next step, the relevant profile range (ROI) should be specified.
- ▷ The options [Define ROI] and [Back] appear on the display.
- ▶ Use [▲] / [▼], to select [Define ROI] or [Back] and press [●].

[Define ROI]: Define the profile range from the taught complete profile.

[Back]: Re-teach the profile.

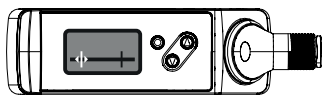

- ▶ Select [Define ROI] with [●].
- ▷ The prompt [Set left ROI mark] appears on the display.
- ▶ Move the green marker line with [▲] / [▼].
- ▷ The right mark moves.
- ▶ Once you have reached the desired position, confirm with [●].
- ▷ The position of the right marker line has been defined.
- ▷ The limited range is re-determined (new profile).



- ▷ The prompt [Set right ROI mark] appears on the display.
- ▶ Move the green marker line with [▲] / [▼].
- ▷ The left mark moves.
- ▶ Once you have reached the desired position, confirm with [●].
- ▷ The position of the left marker line has been defined.

The limited range is re-determined (new profile).



Red line in display: indicates the range determined from the laser line.

White marker: indicates the fixed marker line.

Green arrow marker: indicates the marker line to be moved. Two green projected vertical ROI markers on the laser line support setup.



The standard setting for the relevant profile range (ROI) includes the entire operating range. If the marks are not moved, but only confirmed, then the entire taught profile is used for the evaluation.

#### 8.1.4 SETTING THE POSITION OF THE REFERENCE PROFILE

A reference profile was taught in the previous step from a relevant profile range (ROI). The next step is used to determine in which range the measured height profile should be searched for. There are two selection options here:

##### Fixed:

The reference profile is searched for in the profile range (ROI) specified during the teaching process. During operation, the objects monitored must be positioned exactly as in the teaching process.

##### Floating:

Because of machine and manual related shift tolerances, it is not always possible to position the object being monitored in the correct position. This problem can be avoided by selecting [Floating]. The taught reference profile is searched for in the entire determined height profile. The taught reference profile can be detected successfully despite the position change along the X and Z axis.

Marker function:

During the teach process, the relevant profile range (ROI) is displayed via two green, projected, vertical marker lines (ROI markers).

This indicates to the user which area of the laser line is specified as an ROI. The marker lines are removed once the teach process has ended. They can be displayed manually, however → "11.1 Parameter level basic functions", page 26

- ▶ In the next step, the position of the ROI should be specified.
- ▷ The options [Fixed], [Floating] and [Back] appear on the display.
- ▶ Use [▲] / [▼], to select [Fixed], [Floating] or [Back] and press[●].

[Fixed]: The shifting of the object is not permitted.

[Floating]: The shifting of the object in the X direction (along the laser line) and in the Z direction is permitted.

[Back]: Return to → "8.1.3 Setting the profile range (ROI)", page 17

#### 8.1.5 SWITCHING THRESHOLD

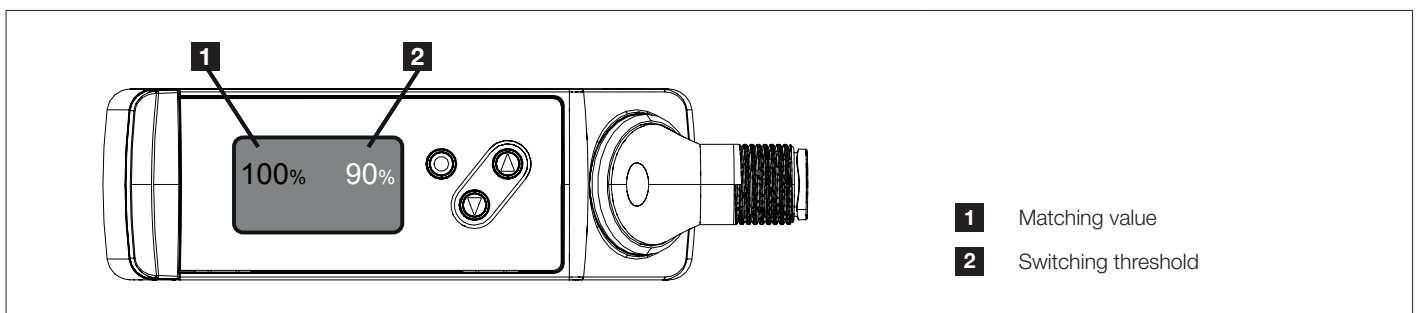



Fig. 8: Switching threshold

- ▶ In the next step, a switching threshold for the switching output should be specified. The switching output default setting is 90%.
- ▷ The sensor continually records new height profiles and compares them to the taught reference profile.
- ▷ The matching value is shown on the display.

-  Matching value > switching threshold (default = 90%), then the measured value appears in green → good part.  
 Matching value < switching threshold (default = 90%), then the measured value appears in red → bad part.  
 Natural fluctuations (noise, drift) are detected in the measured matching value. These measurement fluctuations mean that the matching value itself is normally < 100% for a re-measurement of the taught object.  
 → “3.2.1 Fluctuation of the matching value”, page 8

▷ The options [Adjust threshold], [Save settings] and [Back] appear on the display.

▶ Select with [▲] / [▼] and press [●].

[Save settings]:

– Settings are saved.

[Set threshold]:

– Set the value for the new threshold with [▲] / [▼] and confirm with [●].

-  You can find the optimal setting for your application by testing good parts / bad parts using different switching thresholds. The good part / bad part evaluation is shown on the display.  
 The Advanced functions option can be used to set individual color allocations.  
 Default: green value → good part / red value → bad part

### 8.1.6 SAVING REFERENCE PROFILES

▶ In the next step, the taught reference profile, including all settings made, are saved to one of the 10 memory spaces.

The free / occupied memory locations are designated as follows:

Free memory	Occupied memory
○	●

- [Select the memory location for the current profile]:
- ▶ The memory location can be changed with [▲] / [▼] and confirmed with [●].
- ▶ [Overwrite profile X?]:  
Only appears when the selected memory location is already occupied.
- ▷ The options [No] / [Yes] appear on the display.
- ▶ Select with [▲] / [▼] and confirm with [●].
- ▷ [No]: Return to the previous step.
- ▷ [Yes]: Height profile is overwritten and the sensor is set to the RUN mode.

### 8.1.7 FINISHING THE TEACHING PROCESS

- ▶ [Select the next step]

This step only appears if the selected memory space is available.

- ▷ The options [Go to run mode] / [Add new profile] appear on the display.

- ▶ Select with [▲] / [▼] and confirm with [●].

[Go to run mode]: Initial set-up is complete and the sensor is set to the RUN mode. The newly taught profile is activated for the detection of the matching value.

[Add new profile]: Teaching a new profile → “8.1 Guided teach / Teach process for reference profiles”, page 16

- [Back]: Return to → “8.1.4 Setting the position of the reference profile”, page 18

### 8.1.8 RUN MODE

The sensor is switched to Run mode after set-up via “Guided teach.” The device is now ready for operation.

It continually detects and compares profiles to the activated reference profile based on the set switching threshold.

The result (good part / bad part) is indicated:

- Visually via the display:
  - Good part: Matching value lights up green when the matching value  $\geq$  switching threshold
  - Bad part: Matching value lights up red when the matching value  $<$  switching threshold
- Visually via the switching indicator: Lights up depending on the set function.
- Switching output: OUT1 is switched or not switched depending on the set function.

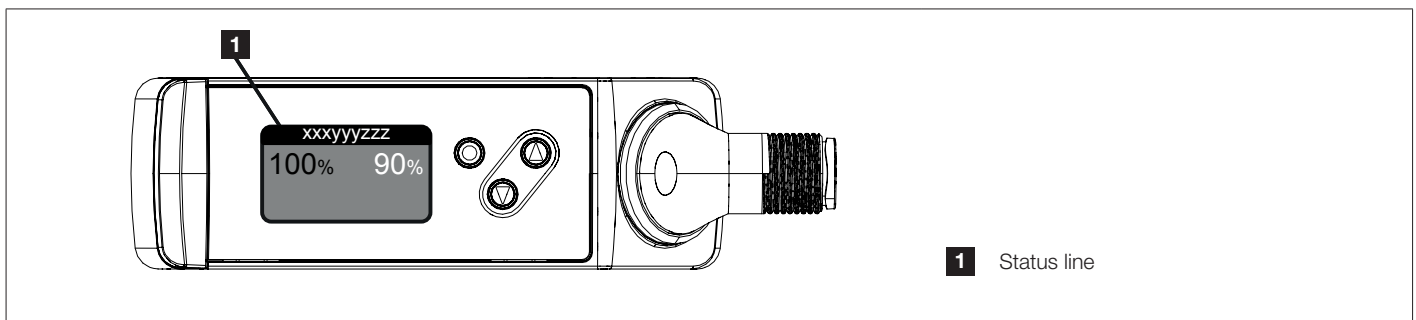

Fig. 9: Status line



The display's status line signals the measurement statuses:

- Profile X: → Uninterrupted operation, continuous mode, activated profile is displayed
- Waiting: → Uninterrupted operation, triggered mode - waiting for trigger signal
- Triggered: → Uninterrupted operation, triggered mode - trigger signal issued
- Warnings / Errors: → “12 Troubleshooting”, page 32

The display color of the matching value is set to green ex works. The display color can be manually changed via the menu → “11.3 [Configuration] submenu”, page 28

# 9 MENU

## 9.1 BASIC FUNCTIONS

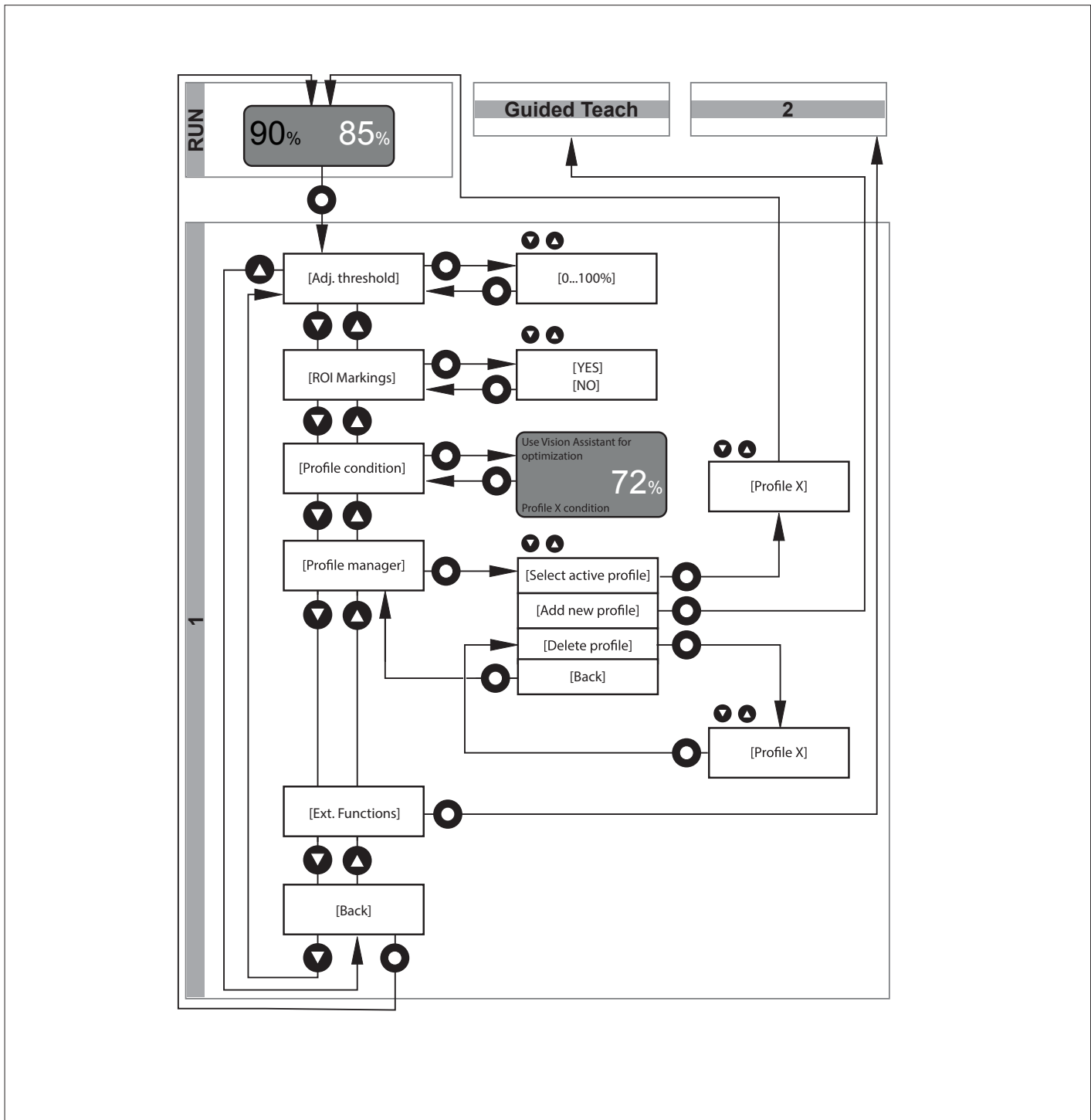

### 9.2 EXTENDED FUNCTIONS

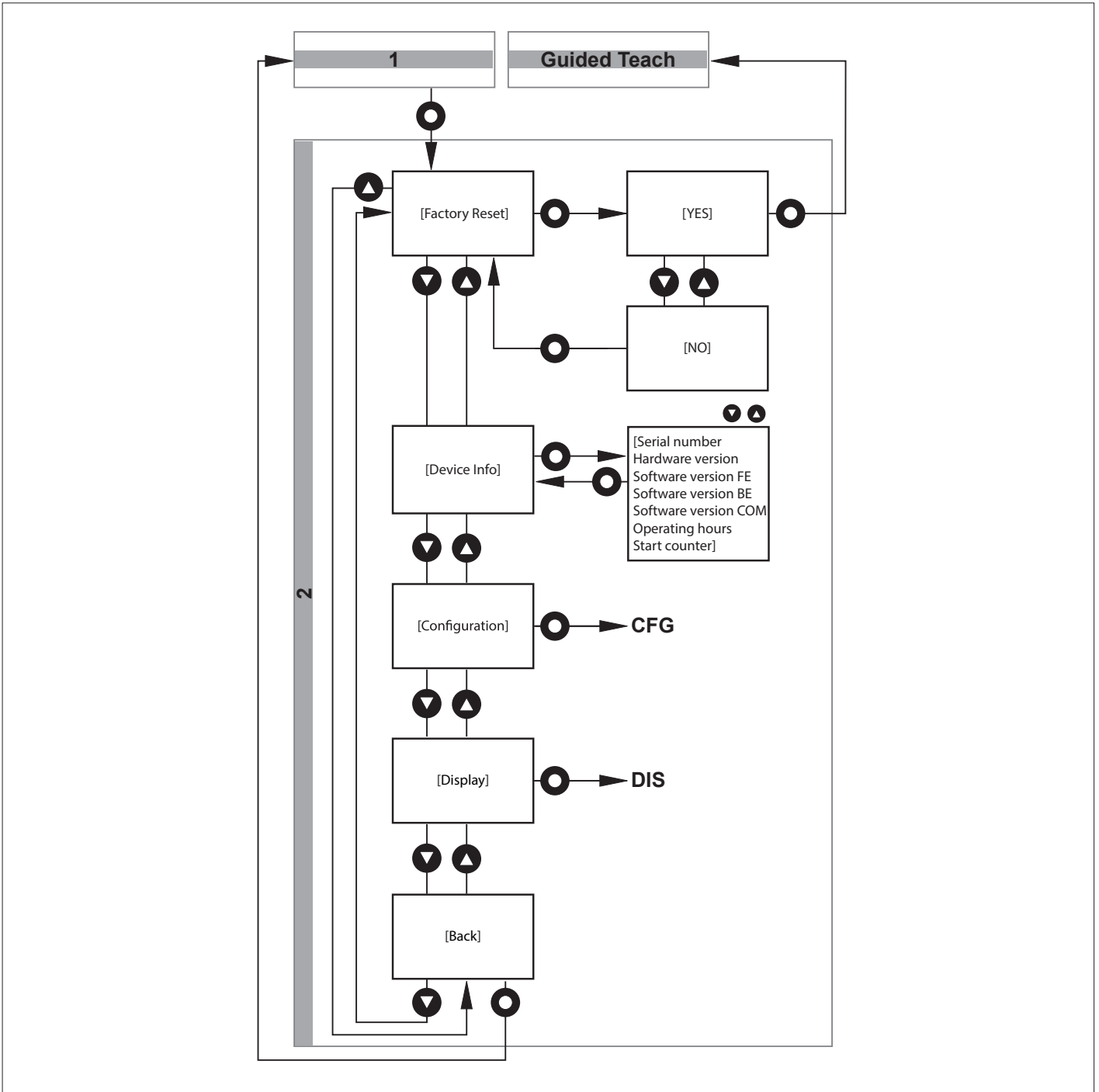

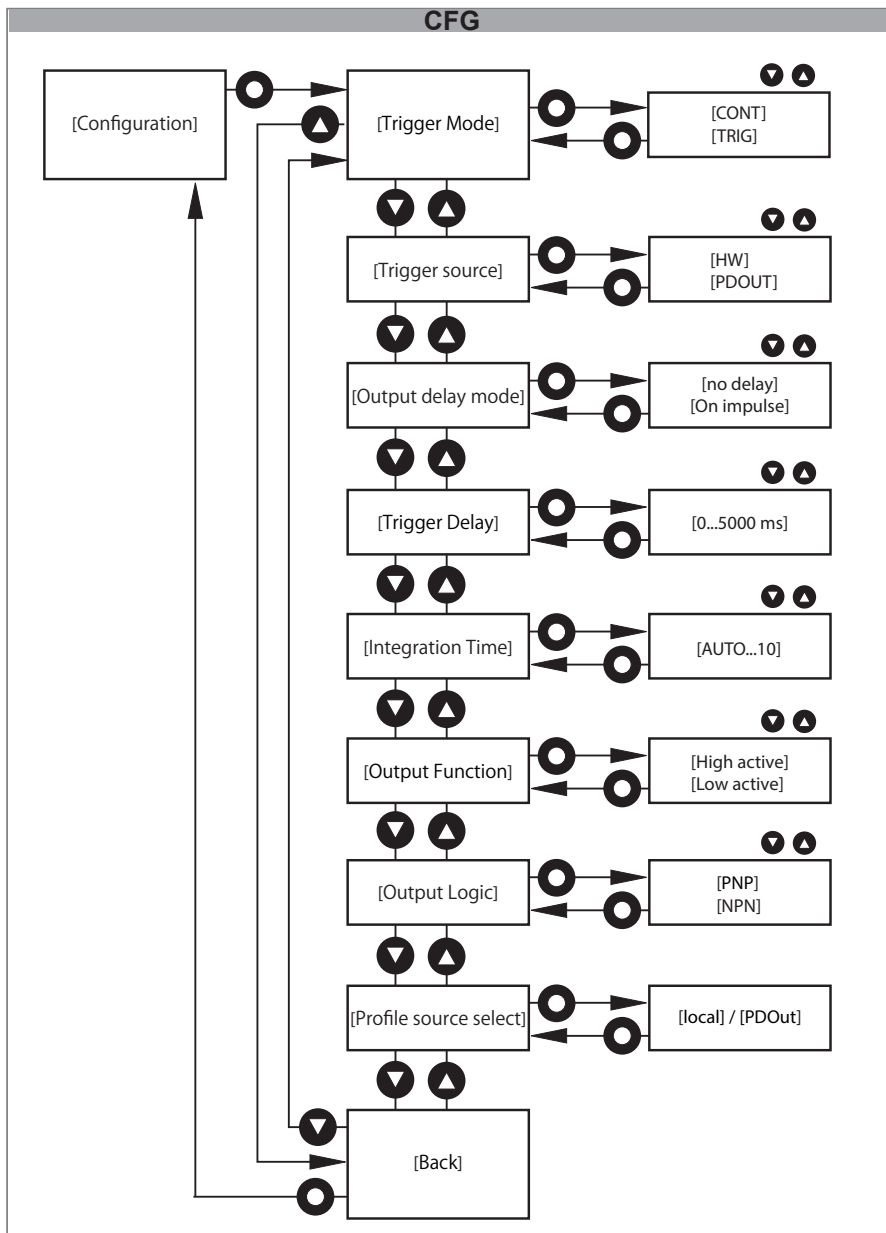

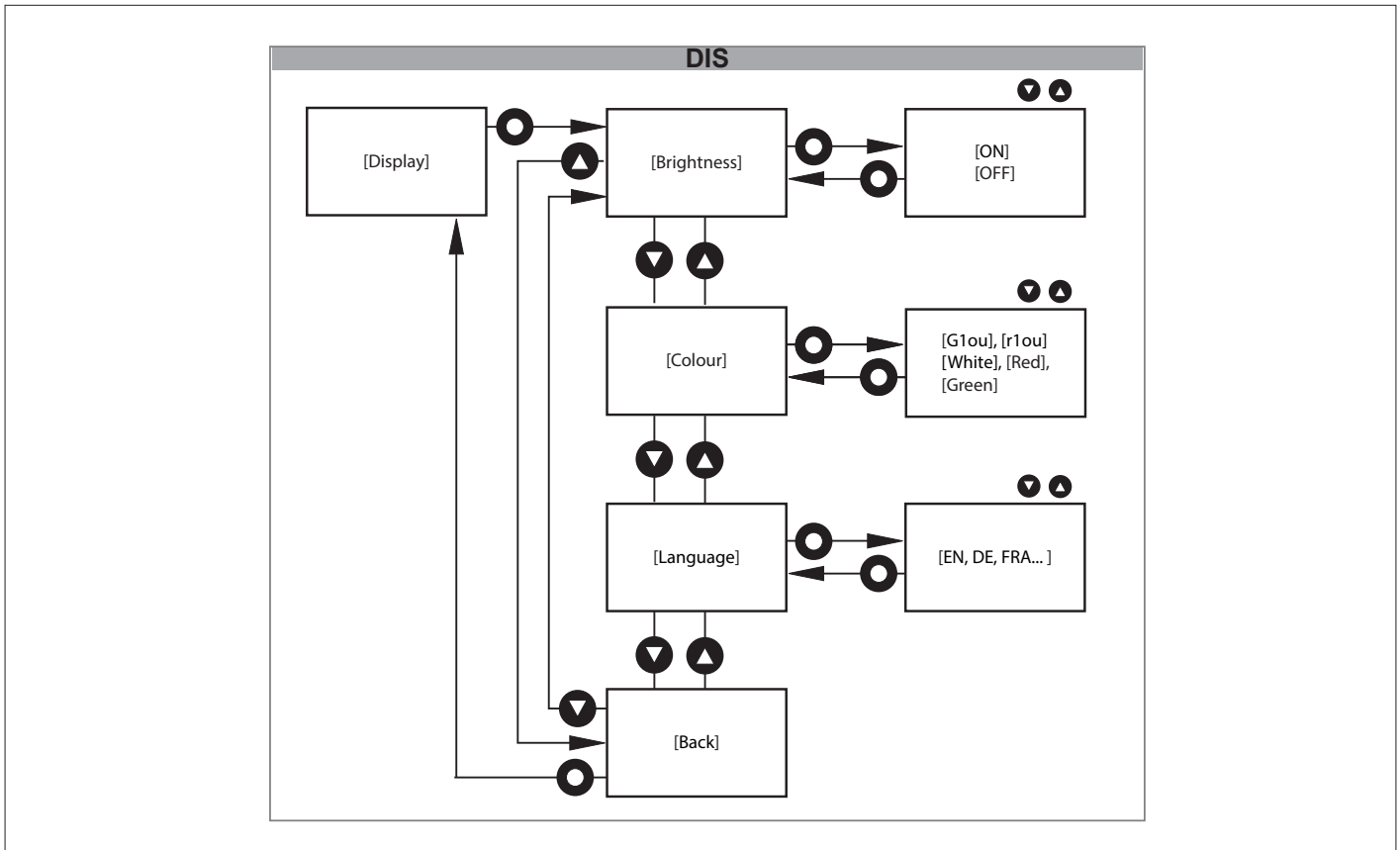

## 10 OPERATING MODES

### 10.1 CONTINUOUS MODE

The “Continuous mode” is the factory setting.

The sensor continually measures and compares the measured profiles, taking into account the switching threshold for the activated reference profile.

### 10.2 TRIGGERED MODE

In this mode, the sensor starts a measurement after receiving an external trigger signal.

The sensor measures and compares the measured profile once, taking into account the switching threshold for the activated reference profile.

The external trigger signal must be provided from the superordinate process control unit (e.g. PLC) and can be transmitted either physically via pin 5 or via IO-Link.

The sensor then signals the successful start and end of the measurement via the ready signal (OUT2) or IO-Link. Meanwhile, the superordinate control unit has full control of the evaluation time period.

The behavior of the switching output (OUT1) can be set via the [Output mode] parameter

→ “11.3 [Configuration] submenu”, page 28

[Output mode] = [no delay]: Sensor reacts to the OUT1 switching output with a static switching signal.

[Output mode] = [On impulse]: Sensor reacts to the OUT1 switching output with a pulsed switching signal.

**!** The signal characteristics and signal values shown here apply to the setting: [Output function] = [high active] and [Output logic] = [PNP] → “11.3 [Configuration] submenu”, page 28



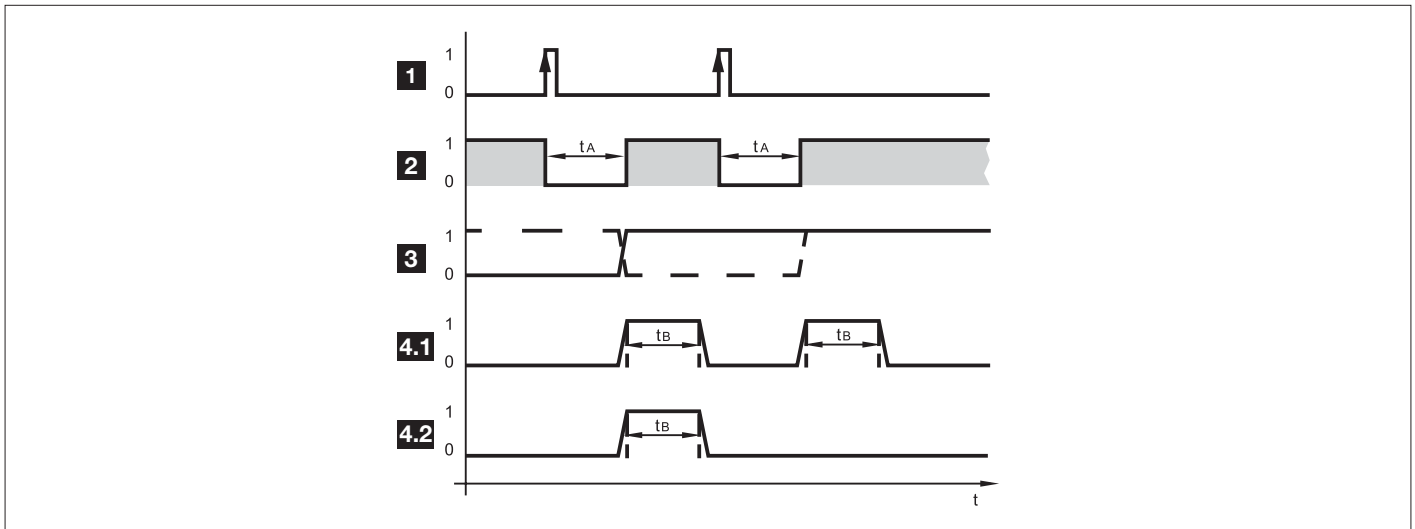



Fig. 10: Example – Triggering positive edge

<b>1</b>	Trigger input	Trigger signal 0: no action 1: Triggering on positive edge	
<b>2</b>	Switching output OUT2	Readiness signal 0: Device busy, Output OUT1 invalid 1: Device ready for trigger signal, output OUT1 valid	
<b>3</b>	Switching output OUT1, static	Test part evaluation 0: Test part is faulty 1: Test part is OK	
		Example 1 (dotted line): Last test part OK, OUT1 = 1 Next test part faulty, OUT1 "1 → 0" Next test part OK, OUT1 "0 → 1"	Example 2 (solid line): Last test part faulty, OUT1 = 0 Next test part OK, OUT1 "0 → 1" Next test part OK, OUT1 = 1
<b>4</b>	Switching output OUT1, pulsed	Test part evaluation 0: Test part is faulty 1: Test part is OK	
		Example 4.1: Both test parts OK, OUT1 = 1 After expiry of $t_B$ , OUT1 = 0 $t_B = 100\text{ms}$	Example 4.2: First test part OK, OUT1 = 1 After expiry of $t_B$ , OUT1 = 0 Second test part faulty, OUT1 = 0 $t_B = 100\text{ms}$

 This operating mode is recommended for dynamic applications in particular. The superordinate process unit first starts a measurement when the object to be evaluated is standing still. The switching output then corresponds exactly to this status of the object.

The [Trigger delay] delays the start of the measurement (relates to the external trigger signal). The ready signal coming from the sensor is not influenced and/or delayed by this.

## 11 PARAMETER SETTING

The device remains in operating mode during parameter setting. It continues to perform its monitoring functions with the existing parameters until the modification has been completed.

The factory settings are listed at the end of these instructions → “11.2.1 [Factory setting]”, page 27

### 11.1 PARAMETER LEVEL BASIC FUNCTIONS

The following parameters can be selected in the parameter level for basic functions:

#### 11.1.1 [ADJUST THRESHOLD]

Setting the switching threshold

- ▶ Confirm the parameter with [●] and use [▲ / ▼] to set the threshold to the desired value.
- ▶ Confirm the value with [●].
- ▷ The new threshold is applied. → “8.1.5 Switching threshold”, page 18

#### 11.1.2 [ROI MARKER]

Turning the display of the ROI marker on the laser line on/off



If a [Fixed] position of the reference profile was selected in the teaching process, the ROI marker then indicates the defined profile range (ROI) defined during the teaching process. If, on the other hand, a [Floating] position was selected, then the ROI marker indicates the entire operating range → “8.1.4 Setting the position of the reference profile”, page 18

- ▶ Confirm parameter with [●] and use [▲ / ▼] to select one of the two options [No] / [Yes].
- ▶ Confirm the selection with [●].
- ▷ The green ROI marker is switched on/off on the laser line depending on the selection.



The marker lines are switched off automatically after approx. 10 min.

To turn them back on:

- ▶ Reset the parameter.

#### 11.1.3 [PROFILE PROPERTIES]

Reading the status parameter.

- ▶ Confirm the parameter with [●].
- ▷ The current value of the status parameter is displayed.
- “3.3 Profile properties”, page 9

#### 11.1.4 [PROFILE MANAGER]

Managing reference profiles.

- ▶ Confirm the parameter with [●] and use [▲ / ▼] to select one of three options [Select active profile], [Add new profile] or [Delete profile].

[Select active profile]:

- ▶ Confirm the parameter with [●].
- ▶ Select the respective profile with [▲ / ▼].
- ▶ Confirm the selection with [●].
- ▷ The display switches to the Run mode.

[Add new profile]:

- ▶ Confirm the parameter with [●].
- ▷ Sensor switches to “Guided teach.”
- ▷ The message [Place object and press confirm] appears on the display. → “8 Set-up”, page 15

[Delete profile]:

- ▶ Confirm the parameter with [●].
- ▶ Select the profile to be deleted with [▲ / ▼].
- ▶ Confirm the selection with [●]

 If the activated profile is to be deleted, a confirmation prompt will appear.  
If the activated profile is deleted, then a matching value can no longer be determined. Corresponding information regarding this appears on the display in Run mode.

 The [Profile manager] menu item is activated when [Profile source select] = local → “11.3 [Configuration] submenu”, page 28  
The [Profile manager] menu item is disabled when [Profile source select] = PDOOut → “11.3 [Configuration] submenu”, page 28  
In the last situation, the settings can only be made via IO-Link.

### 11.1.5 [EXTENDED FUNCTIONS]

Switch to the menu level for → “9.2 Extended functions”, page 22

#### 11.1.6 [BACK]

- ▶ Confirm the parameter with [ENTER].
- ▷ The display switches to the Run mode.

## 11.2 PARAMETER LEVEL EXTENDED FUNCTIONS

---

The following parameters can be selected in the parameter level for extended functions:

### 11.2.1 [FACTORY SETTING]

Reset all parameters to the factory setting.

- ▶ Confirm parameter with [●] and use [▲ / ▼] to select one of the two options [NO] / [YES].
- ▶ Select [YES] and confirm with [●].
- ▷ The sensor resets all parameters to the factory setting and switches to “Guided teach.”

### 11.2.2 [DEVICE INFORMATION]

Sensor information

- ▶ Confirm the parameter with [●] and use [▲ / ▼] to navigate through the information lines.

### 11.2.3 [CONFIGURATION]

Operating mode and switching output configuration → “11.3 [Configuration] submenu”, page 28

- ▶ Confirm the parameter with [●].
- ▷ Display switches to the configuration settings.
- ▶ Use [▲ / ▼] to select one of the following options.
  1. [Triggered mode]
  2. [Trigger source]
  3. [Trigger delay]
  4. [Integration time]
  5. [Output function]
  6. [Output logic]
  7. [Profile source select]
  8. [Back]

### 11.2.4 [DISPLAY]

Display configuration

- ▶ Confirm the parameter with [●].
- ▷ Display switches to the display settings.
- ▶ Use [▲ / ▼] to select one of the following options.
  1. [Brightness]
  2. [Color]
  3. [Language]
  4. [Back]

### 11.2.5 [BACK]

Finish parameter setting

- ▶ Confirm the parameter with [ENTER].
- ▷ Display switches to menu level 1.

## 11.3 [CONFIGURATION] SUBMENU

---

### 11.3.1 [TRIGGERED MODE]

Set operating mode

- ▶ Confirm parameter with [●] and use [▲ / ▼] to select one of the two options [CONT] / [TRIG].
- ▶ Confirm the selection with [●].
- ▷ The operating mode is applied.
  - [CONT]: Continual trigger mode → page 24
  - [TRIG]: Triggered mode → page 24

### 11.3.2 [TRIGGER SOURCE]

Setting the source for the trigger signal

- ▶ Confirm parameter with [●] and use [▲ / ▼] to select one of the two options [HW] / [PDOOUT].
- ▶ Confirm the selection with [●].
- ▷ The input signal is applied.
  - [HW]: Create the input signal via pin 5. The logic levels (npn / pnp) are defined under [Output logic].
  - [PDOOUT]: The input signal is transmitted via the IO-Link master (IO-Link operation).



The menu item is activated when [Triggered mode] = [TRIG].

### 11.3.3 [OUTPUT MODE]

Setting the behavior of switching signal OUT1

- ▶ Confirm parameter with [●] and use [▲ / ▼] to select one of the two options [no delay] / [On impulse].
- ▶ Confirm the selection with [●].
- ▷ The behavior of switching signal OUT1 is applied.
  - [no delay]: static switching signal OUT1
  - [On impulse]: pulsed switching signal OUT1



The menu item is activated when [Triggered mode] = [TRIG].

### 11.3.4 [TRIGGER DELAY]

Setting the delay time for the trigger signal until the start measurement

- ▶ Confirm the parameter with [●] and use [▲ / ▼] to select the value (0 - 5000 ms).
- ▶ Confirm the selection with [●].
- ▷ The delay time is applied.



The menu item is activated when [Triggered mode] = [TRIG].

### 11.3.5 [INTEGRATION TIME]

Setting the exposure time

- ▶ Confirm the parameter with [●] and use [▲ / ▼] to select one of the two options [Auto] / [0 - 10 ms].
- ▶ Confirm the selection with [●].
- ▷ The exposure time is applied.



The exposure time of the sensor is determined and regulated automatically for the [Auto] factory setting. A fixed setting for the integration time can make sense if a dark ROI needs to be evaluated in the middle of reflecting surfaces.

### 11.3.6 [OUTPUT FUNCTION]

Setting for the OUT1 switching function

- ▶ Confirm parameter with [●] and use [▲ / ▼] to select one of the two options [High active] / [Low active].
- ▶ Confirm the selection with [●].
- ▷ The output function is applied for OUT1.
  - [High active]: OUT1 is switched when matching value > switching threshold.
  - [Low active]: OUT1 is switched when matching value < switching threshold.
  - In the [CONT] trigger mode, OUT2 is set automatically as the complementary switching output to OUT1.

### 11.3.7 [OUTPUT LOGIC]

Setting the switching logic for all input and outputs

- ▶ Confirm parameter with [●] and use [▲ / ▼] to select one of the two options [PNP] / [NPN].
- ▶ Confirm the selection with [●].
- ▷ The switching logic is applied.

### 11.3.8 [PROFILE SOURCE SELECT]

Information output for the selection source of the reference profile

- ▶ Confirm the parameter with [●].

[local]: An active reference profile can be determined via the Display menu → page 26 “Parameter level basic functions”

- [PDOut]: The active profile is defined via IO-Link.



The selection source [local] / [PDOut] is defined exclusively via IO-Link.  
Factory setting = [local]

### 11.3.9 [BACK]

Finish parameter setting

- ▶ Confirm the parameter with [●].
- ▷ Display switches to [Configuration].

## 11.4 [DISPLAY] SUBMENU

---

### 11.4.1 [BRIGHTNESS]

Setting the display brightness

- ▶ Confirm parameter with [●] and use [▲ / ▼] to select one of the two options [ON] / [OFF].
- ▶ Confirm the selection with [●].
- ▷ The display brightness is applied.



The [OFF] setting turns the display off 20 s after the last button was pressed. The display reactivates once a button is pressed again.

### 11.4.2 [COLOR]

Setting the display color for the matching value

- ▶ Confirm the parameter with [●] and use [▲ / ▼] to select the desired option.
- ▶ Confirm the selection with [●].
- ▷ The display color for the matching value is applied.

Options:

- [G1ou]: green = good part
- [r1ou]: red = good part
- [White]: matching value always white
- [Red]: matching value always red
- [Green]: matching value always green

### 11.4.3 [LANGUAGE]

Selecting the menu language

- ▶ Confirm the parameter with [●] and use [▲ / ▼] to select one of the options.
- ▶ Confirm the selection with [●].
- ▷ The menu language is applied

### 11.4.4 [BACK]

Finish parameter setting

- ▶ Confirm the parameter with [●].
- ▷ Display switches to [Display].

## 11.5 IO-LINK

---

### 11.5.1 GENERAL INFORMATION

This device has an IO-Link communication interface, which is required for the operation of an IO-Link-capable module (IO-Link master). The IO-Link interface enables direct access to sensor values and parameters, and gives you the option of making parameter settings to the device during operation.

In addition, communication via a point-to-point connection is also possible with a USB adapter cable.

For more information about IO-Link, visit [www.di-soric.com](http://www.di-soric.com).

### 11.5.2 DEVICE-SPECIFIC INFORMATION

The IO-DDs required to configure the IO-Link device as well as detailed information about sensor values, diagnostic information and parameters can be found in an overview table at [www.di-soric.com](http://www.di-soric.com).

### 11.5.3 PARAMETER SETTING TOOLS

All required information regarding the required IO-Link hardware and software can be found at [www.di-soric.com](http://www.di-soric.com) → 213740 → Downloads.

### 11.5.4 FUNCTIONAL SCOPE

All functions and measurement data are also available in IO-Link that are available via the display and buttons accessed directly on the device.

All functions are described in detail in the IO-DD.

## 12 TROUBLESHOOTING

### 12.1 ERROR MESSAGES ON THE DISPLAY

Display	Possible cause	Solution
Profile X	Sensor is in normal operation. There is no fault.	No action required
Object out of range	Object is located outside (too far / too close) of the operating range. Height profile and matching value cannot be determined.	Increase / Decrease distance to object. A detected profile must be in the operating range 150 - 300 mm.
Short circuit at OUT1	Short circuit at switching output 1	Check wiring.
Short circuit at OUT2	Short circuit at switching output 2	Check wiring.
Laser off	Laser was turned off by the user.	Turn on laser (Pin 5 / IO-Link)
No active profile	A free memory location was activated via IO-Link.	Activate an occupied memory location
---	No active profile selected	Activate a reference profile → <b>"11.1 Parameter level basic functions", page 26</b> If [Profile source select] = [PDout]: Activate a reference profile via IO-Link. This is signaled on the display with [Remote].

### 12.2 OTHER ERRORS

Situation	Possible cause	Solution
Object cannot be taught. "Object out of range" is reported even though the object is in the operating range of 150 - 300 mm.	Due to the front displacement of the sensor and condition of the object / background, some reflected laser beams cannot reach the receiver. → <b>"5.2.2 Front inclination", page 12</b>	<ul style="list-style-type: none"> <li>▶ Change the sensor position slightly (front inclination, reduce / increase spacing to object).</li> <li>▶ If possible, rotate the sensor or workpiece 180°.</li> </ul>
Sensor was taught successfully. However, the matching value is very low (also for the taught object).	Sensor was moved after the teaching process. Info: The sensor should no longer be moved after a successful "Guided teach" teach process. The taught reference profile will no longer be reliably detected any time there is a change to the position.	<ul style="list-style-type: none"> <li>▶ Re-teach the sensor.</li> </ul>
Sensor was taught successfully. However, the matching value is significantly lower than 90% for very similar workpieces.	The new workpieces can have a slightly deviating surface quality, e.g. reflective surfaces.	<ul style="list-style-type: none"> <li>▶ Tilt sensor slightly frontally or vertically and re-teach.</li> <li>▶ Or check whether the width of the reference profile can be limited further. Then re-teach the sensor.</li> <li>▶ Or manually adjust the [Integration time].</li> <li>▶ Or reduce the switching threshold.</li> </ul>
Sensor has been in operation for some time. Good parts are being evaluated as bad parts. The matching value is below the set switching threshold.	Sensor was moved by accident.	<ul style="list-style-type: none"> <li>▶ Re-teach the sensor.</li> </ul>
	Front side of the sensor is dirty.	<ul style="list-style-type: none"> <li>▶ Clean the front side of the sensor.</li> <li>▶ If necessary, change the sensor alignment to avoid soiling and re-teach the sensor.</li> </ul>



## 13 MAINTENANCE, REPAIRS, DISPOSAL

Defective sensors may only be repaired by the manufacturer.

- ▶ Keep the front panel of the device free of soiling.
- ▶ The device should be disposed after use in an environmentally-friendly manner according to any valid national regulations.
- ▶ Do not open the module housing. It does not contain any components that can be maintained by the user himself.

## 14 DIMENSIONAL DRAWING

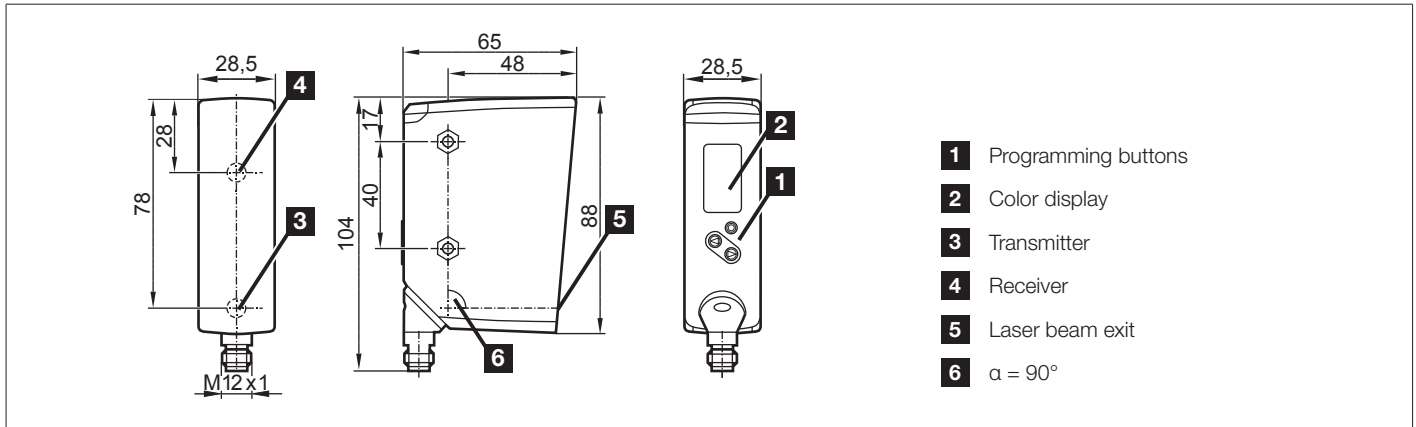

Fig. 11: Scale drawing - dimensions in [mm]

## 15 FACTORY SETTING

Parameters	Adjustment range	Factory setting	Other setting
Switching threshold [%]	0 to 100	90	
Display of ROI marker in run mode	YES / NO	NO	
Operating mode (trigger mode)	CONT (continuous measurement) / TRIG (external trigger)	CONT	
Trigger source	HW / PDOUT	HW	
Trigger delay [ms]	0; 10 to 5000	0	
Integration time	Auto; 1; 2 to 10	Auto (automatically controlled by sensor)	
Output function	High active Low active	High active	
Output logic	PNP / NPN	PNP	
Brightness	ON / OFF	ON	
Color	G1ou; r1ou; White; Red; Green	G1ou	
Language	EN; DE; FR; ...	EN	
Profile source select (can only be set via IO-Link)	local / PDOut	local	

**SOLUTIONS. CLEVER. PRACTICAL.**

di-soric GmbH & Co. KG | Steinbeisstrasse 6 | 73660 Urbach | Germany  
Phone +49 71 81 98 79-0 | Fax +49 71 81 98 79-179 | info@di-soric.com

**[www.di-soric.com](http://www.di-soric.com)**